

We Are in Space



We are in Space, 2020
Visualisierung der Installation am Standort in Isafjörður, Island



We are in Space, 2020
Zeichnung aus dem künstlerischen Konzept

Abb.1 Axonometrie Landeanlage



Abb.2 Detail Turm-Kopf



Abb.1: **A** | Dodekaeder (siehe Abb.2), **B** | Stützenkonstruktion aus KVH (nach statischen Erfordernissen, z.B. geteilte Stütze 60x100mm Elementquerschnitt, **C** | Abspannung, Zugseile mit Ankerschrauben und Spannschloss, **D** | Kreuzfuss mit Kopfbänder als Zangenkonstruktion ausgeführt, verschraubt, mit Balken-Konsolen gelagert, luftumspült, **E** | Gründung nach Bodengutachten z.B. Bohranker verpresst mit Zugseilkonstruktion verspannt

Abb.2: **1** | Pentagon Fläche, Trägerplatte (ggf. Alu-Dipond), Spiegelfolie. **2** | Spacer, Aluminium, 2 Zoll Rohr, Kopfplatten ggf. verschweißt. **3** | Kern-Dodekaeder, Multiplex-Platte 21mm, **4** | Verkaterung, KVH zur äußeren Verschrauben des Körpers erforderlich. **5** | Konterplatte Aluminium, für Spacer-Konstruktion mit Gewindebolzen

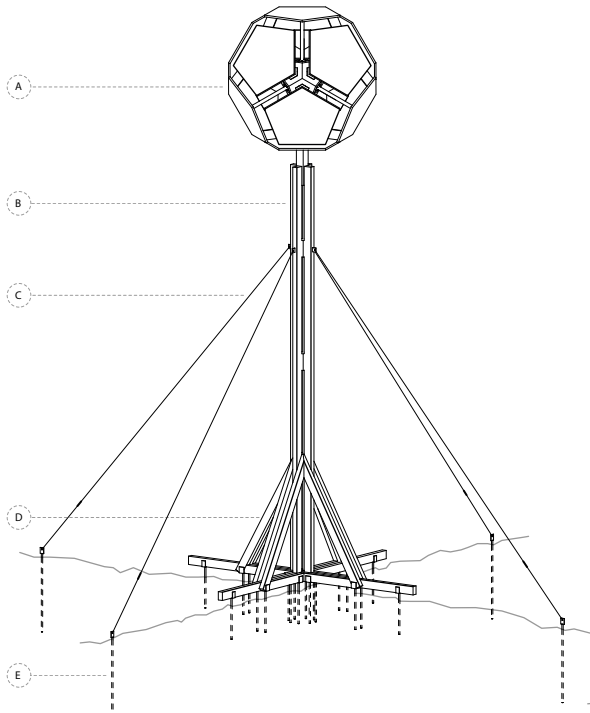
Abb.3 Aufsicht Landeanlage

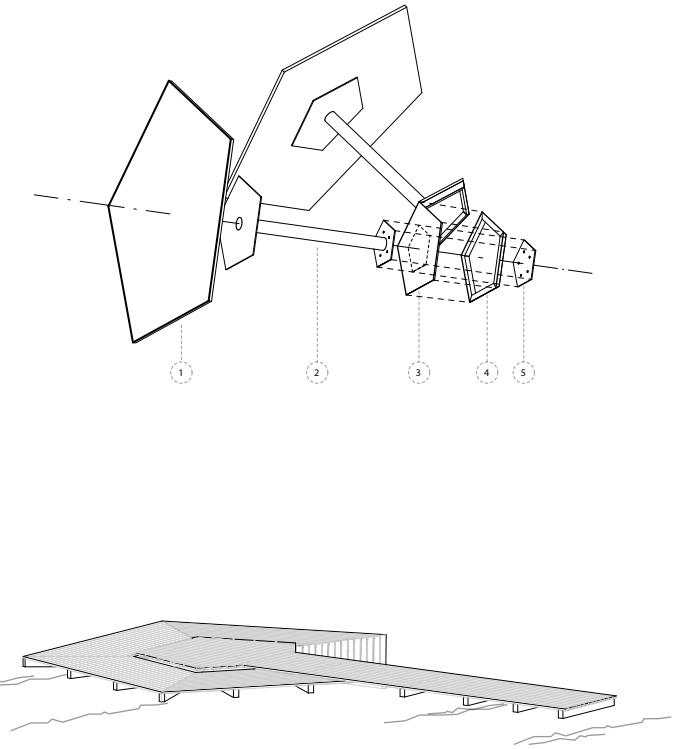

Abb.4 Ansicht Turm



Björn Dahlem

We are in Space, 2020

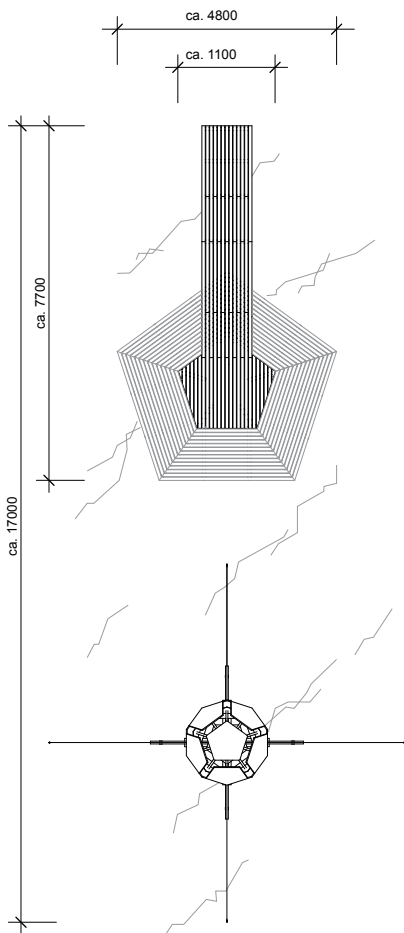
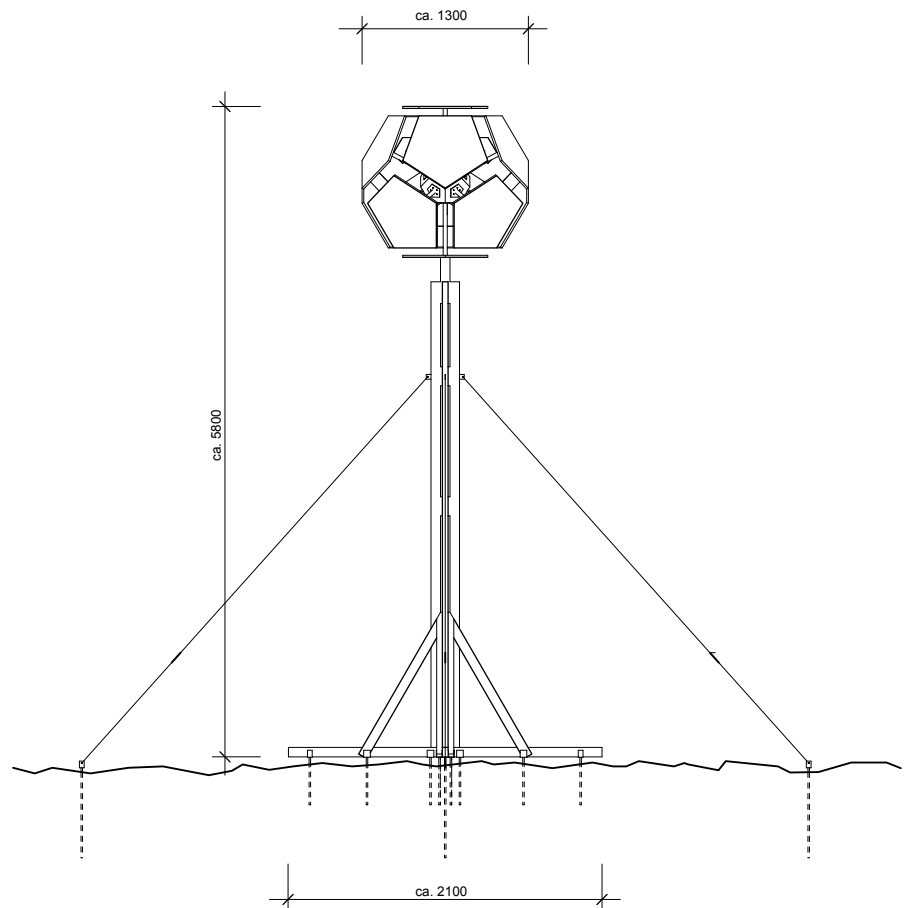
Artistic Concept

The installation *We are in Space* is meant to be a monument of openness and a mental gate to the universe. While many people believe, universal space is something “far outside”, it is a matter of fact that we are *i n s i d e* the universe.

The installation is a landmark in the unique scenery of Isarfjörður (Iceland), establishing a location on earth where people mentally connect to the universe, to alien thoughts, to the vastness of empty space, to billions of galaxies surrounding us, to alien minds and maybe even physical alien visitors. A place to raise the awareness, that universal space is not a place “far outside” but in fact the place that we all inhabit.

Formally the installation and its sculptural components derive from dodecahedron shapes, as the dodecahedron is the ancient symbol of the mysterious fifth element, the element of the skies and thereby represents extraterrestrial strength and mystery.

Technical Structure

The structure of the installation mainly consists of wooden beams and boards (standard construction wood). There are two elements of the structure: the landing pad, which is a flat, pentagonal platform, consisting of a grid of wooden beams. Diameter of the pad is about 400 cm, its height about 12 cm. The pad is covered by a low, black stained footbridge leading to a black pentagon in the middle of the pad. The tower, which is an approximately 450 cm rising foot with a dodecahedron shaped, mirrored sphere on top (diameter approx. 130 cm), has a total height of about 580 cm. The tower is fixed by concrete foundation or floor anchoring (in rocky ground). For additional stability four steel cables are fixed from the tower to anchoring in the ground.

The installation consists of low-tech and simple materials, which are always typical for my work. Technical construction is meant to be simple but safe and fulfilling all standards of security aspects. The installation is meant to be ephemeral and be removed or re-installed after a certain time (five to ten years).

You can see the approximate measurements in the technical sketches (image 2+3).